

Alle nicht tolerierten Maße sind Richtwerte. [All non-tolerated dimensions are guide values.]
 Technische Änderungen grundsätzlich vorbehalten. [We reserve the right to make technical changes.]

Y (2:1)

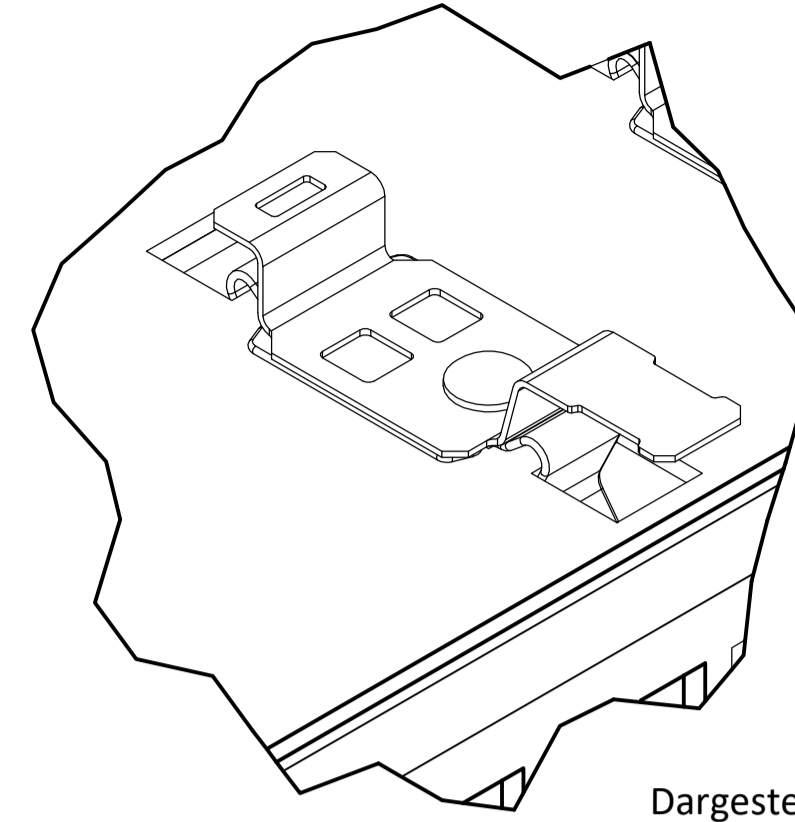
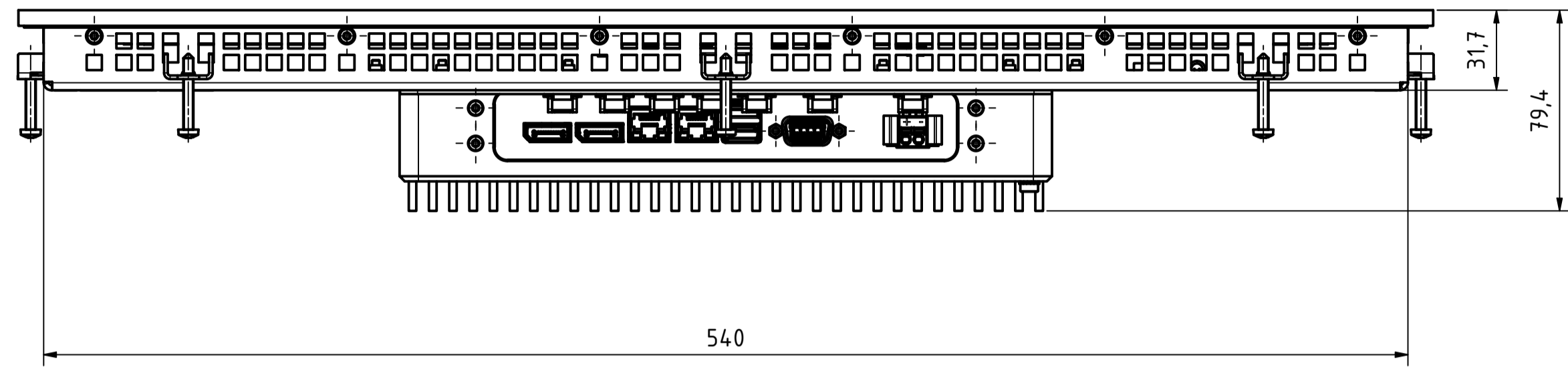

Dargestellte Zugentlastungen sind nicht im Lieferumfang enthalten.
 [The shown strain reliefs are not included.]

Order number: 64-196-296 HEBOCLIP 1035-024C / HLZ 8/12 LOCHBLECH

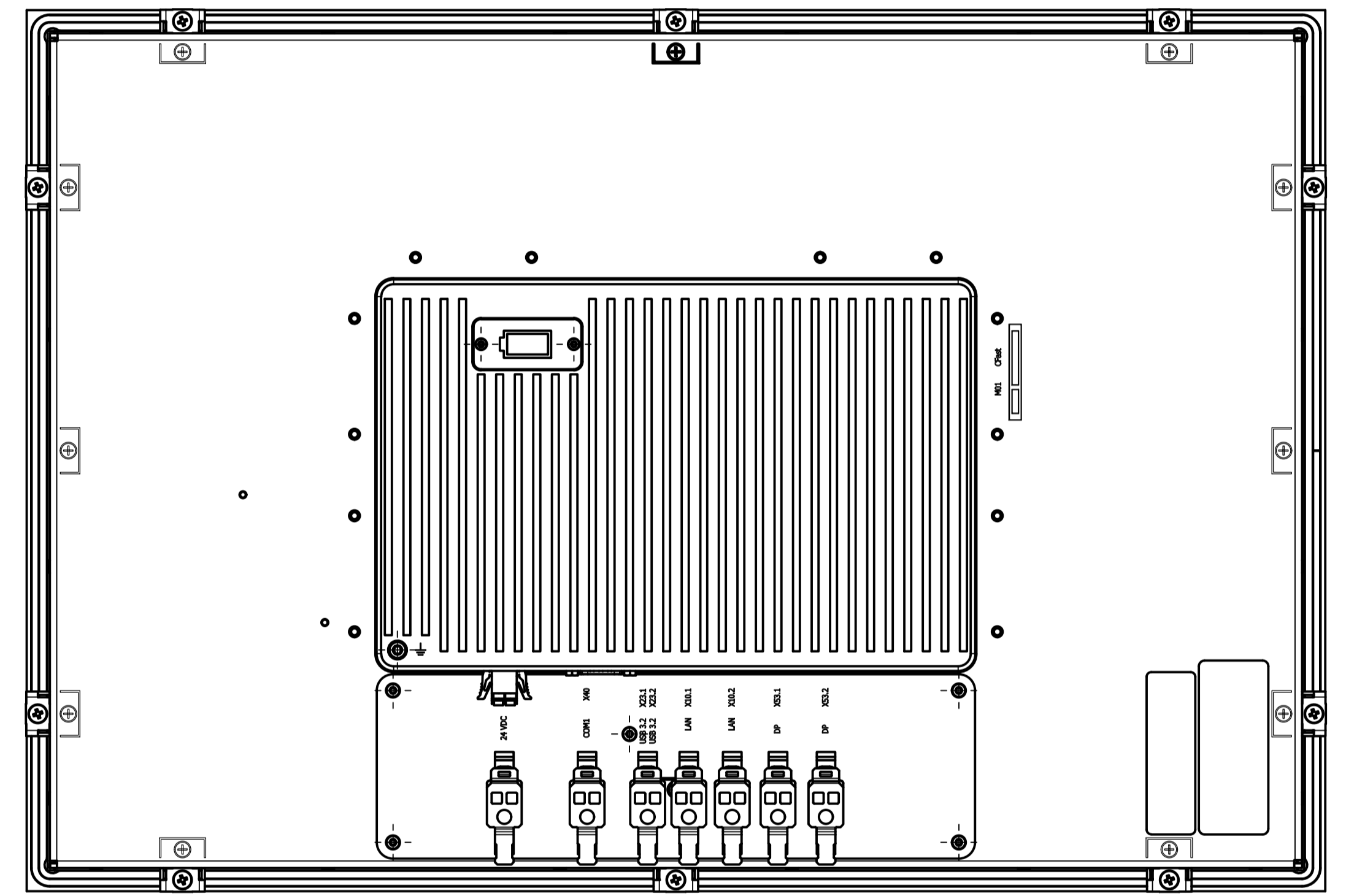
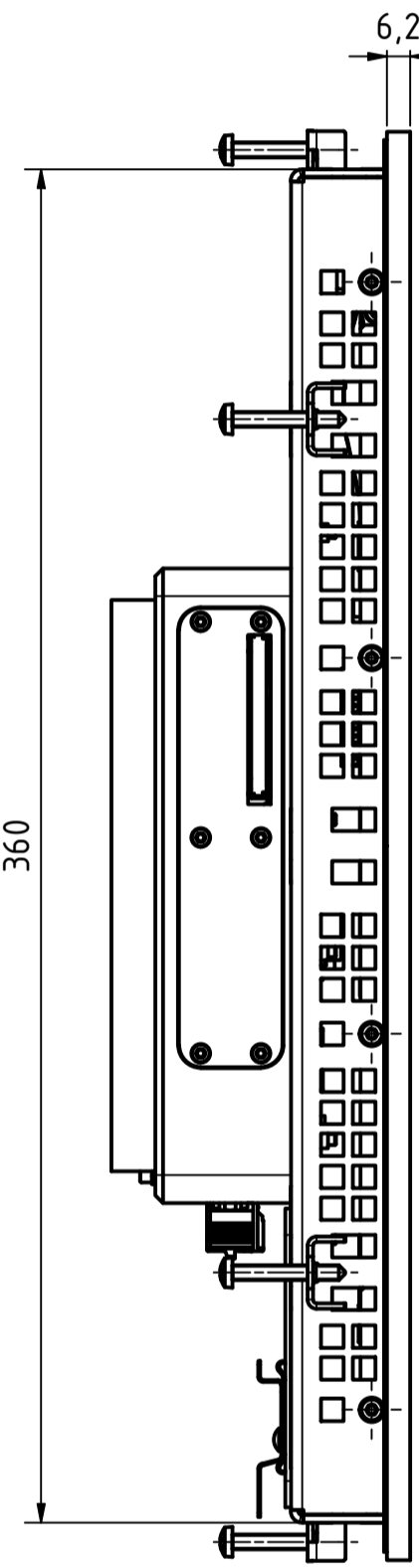
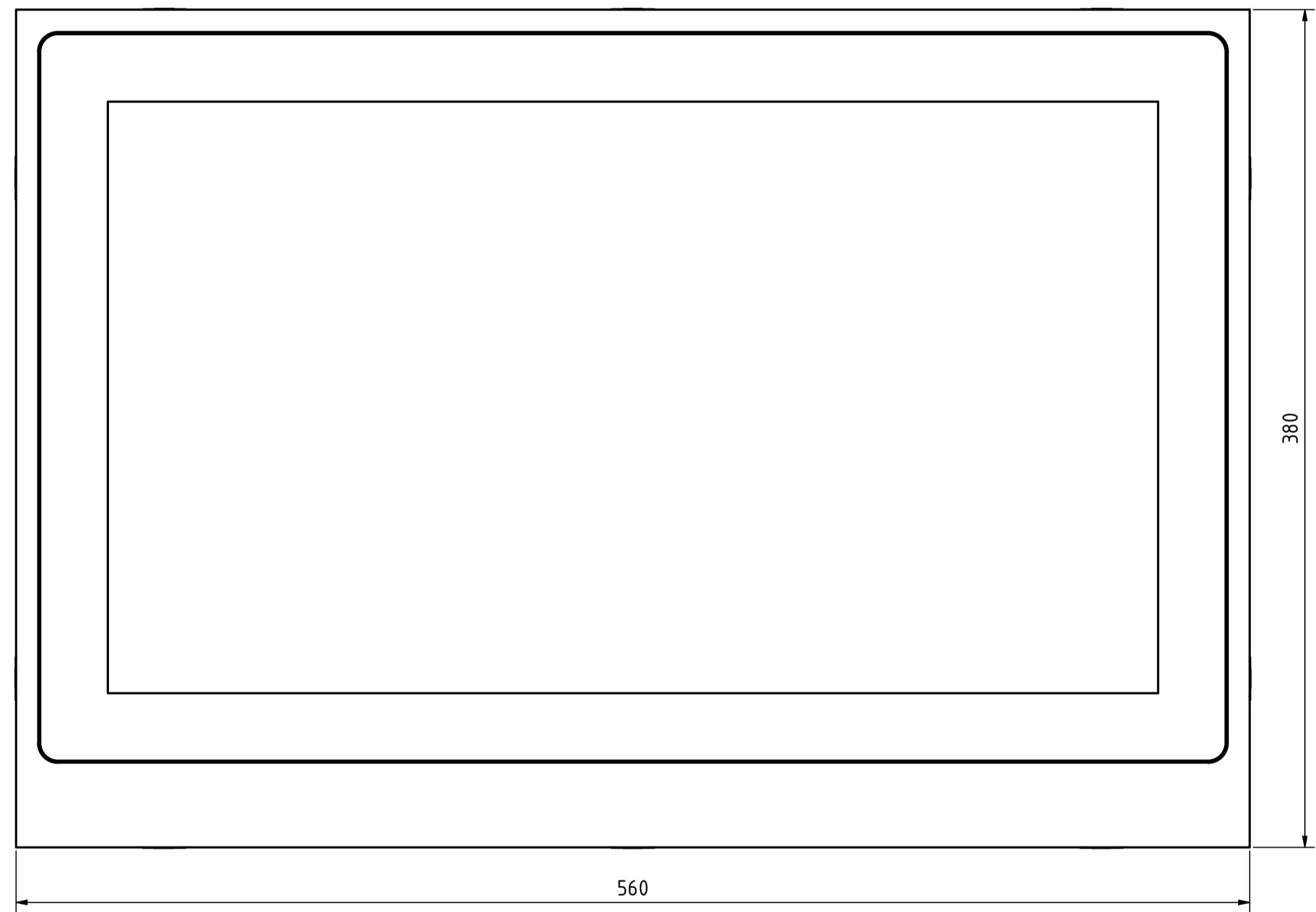
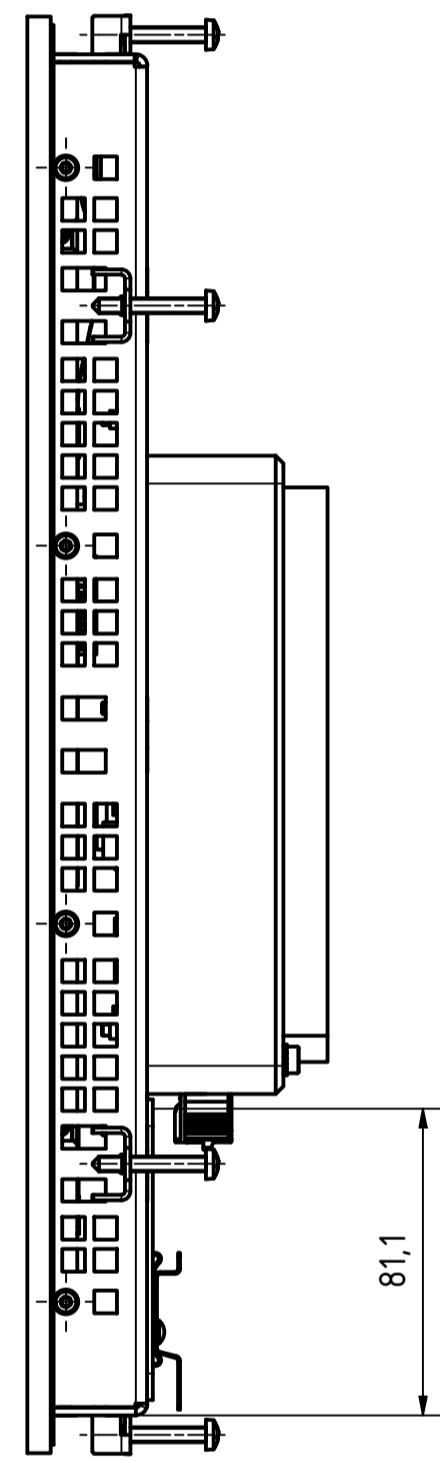

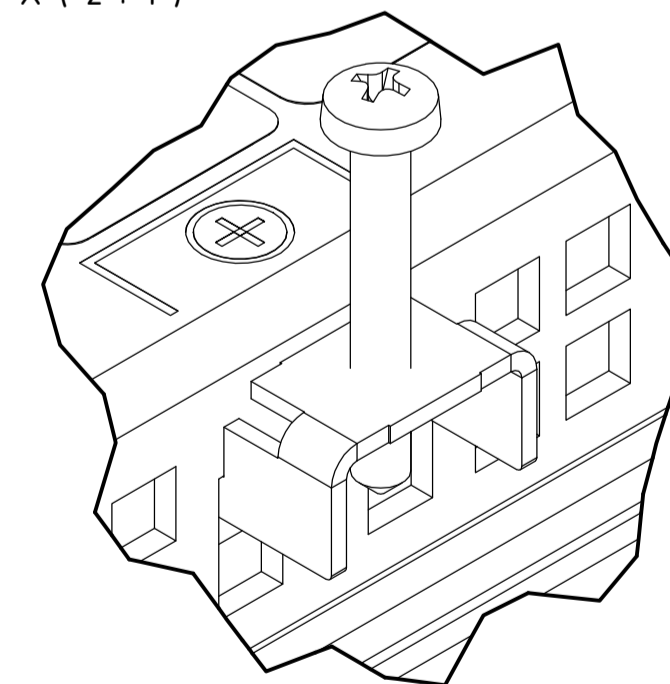

X (2:1)

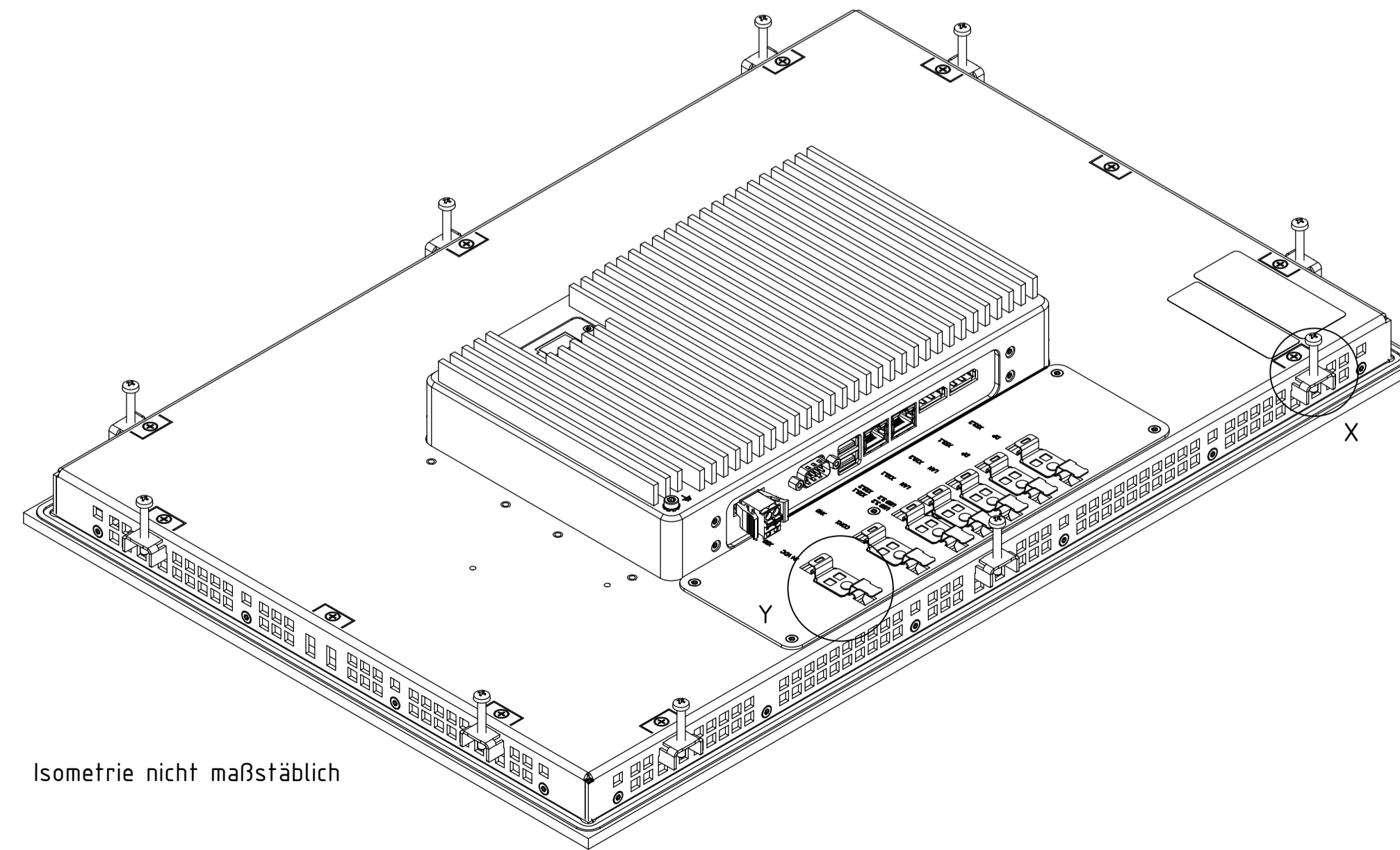
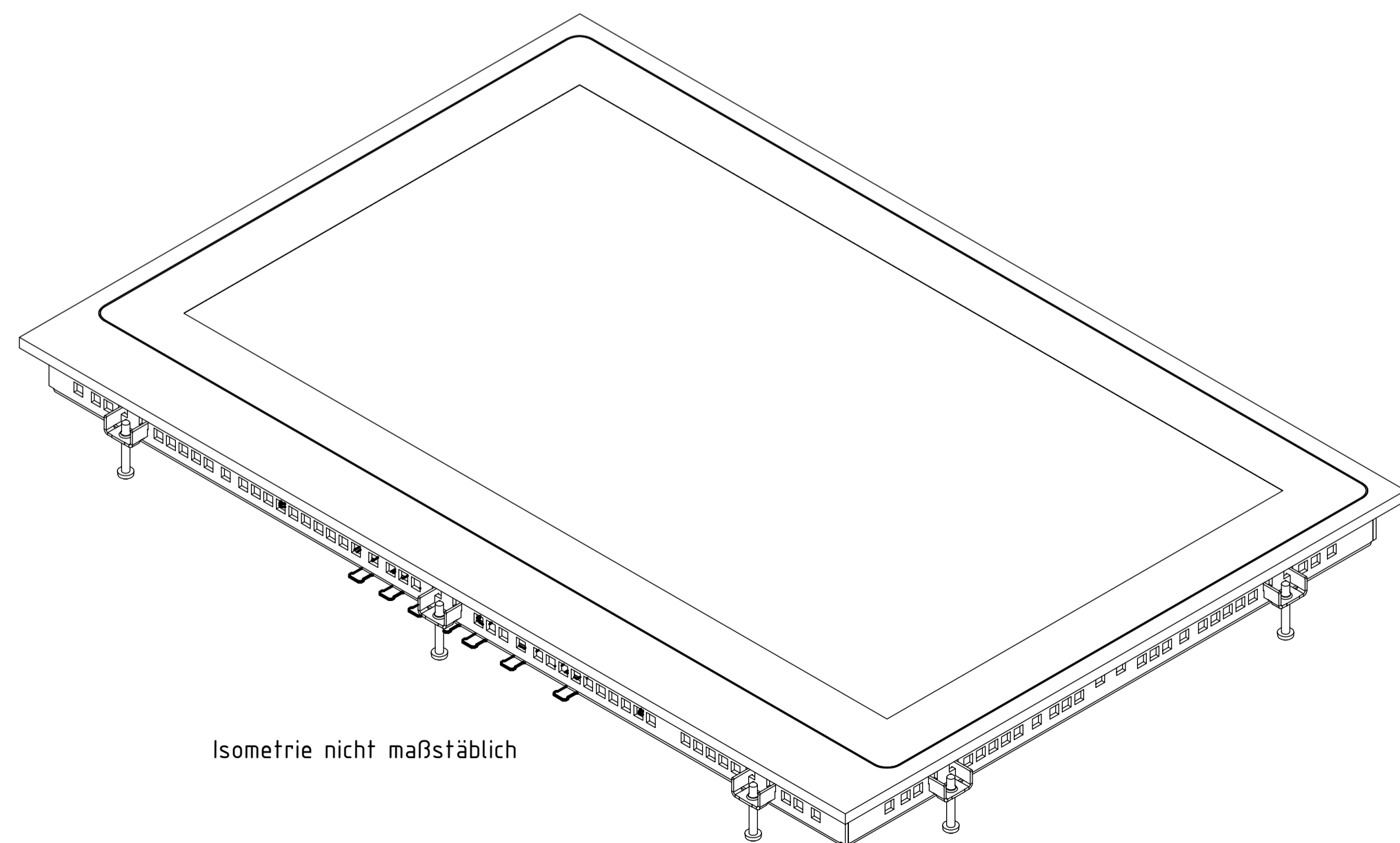

Dargestellte mounting clips sind nicht im Lieferumfang enthalten.
 [The shown Mounting clips are not included.]

Order number: 778-90247 notion.S Mounting clips (set = 20 pcs.)



Tolerierung (Tolerancing) ISO 8015		alle Maße in mm (all dimensions in mm)		Maßstab (Scale) 1:2	DIN A1
E-Mail: info@trsystems.de		CAD: STEP			
	Datum	Name	Bezeichnung (Designation):		
	Erst	25.08.2025	BLESSING	_NOTION.S_CPU7_21,5 (FULLHD)	
	Bearb.	25.08.2025	BLESSING		
	Gepr.	10.09.2025	AIPLE		
	Norm				
	 TRsystems GmbH Eggenhalden 16 D-78647 Trossingen Tel. +49 7425 228-0 www.trsystems.de			Zeichnung-Nr. (Drawing-No.)	
				778-11970-00	
Zust.	Änderungen	Datum	Name	Dok.-Art. IDW	Teil.-Dok. 000
				Dok.-Vs. 00	1/2 Bl.

i Alle nicht tolerierten Maße sind Richtwerte. [All non-tolerated dimensions are guide values.]
 Technische Änderungen grundsätzlich vorbehalten. [We reserve the right to make technical changes.]

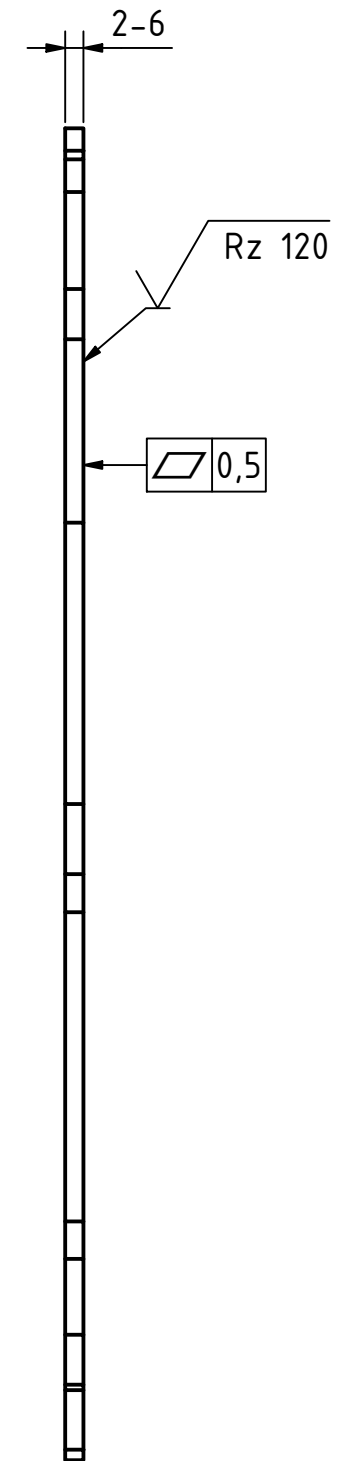
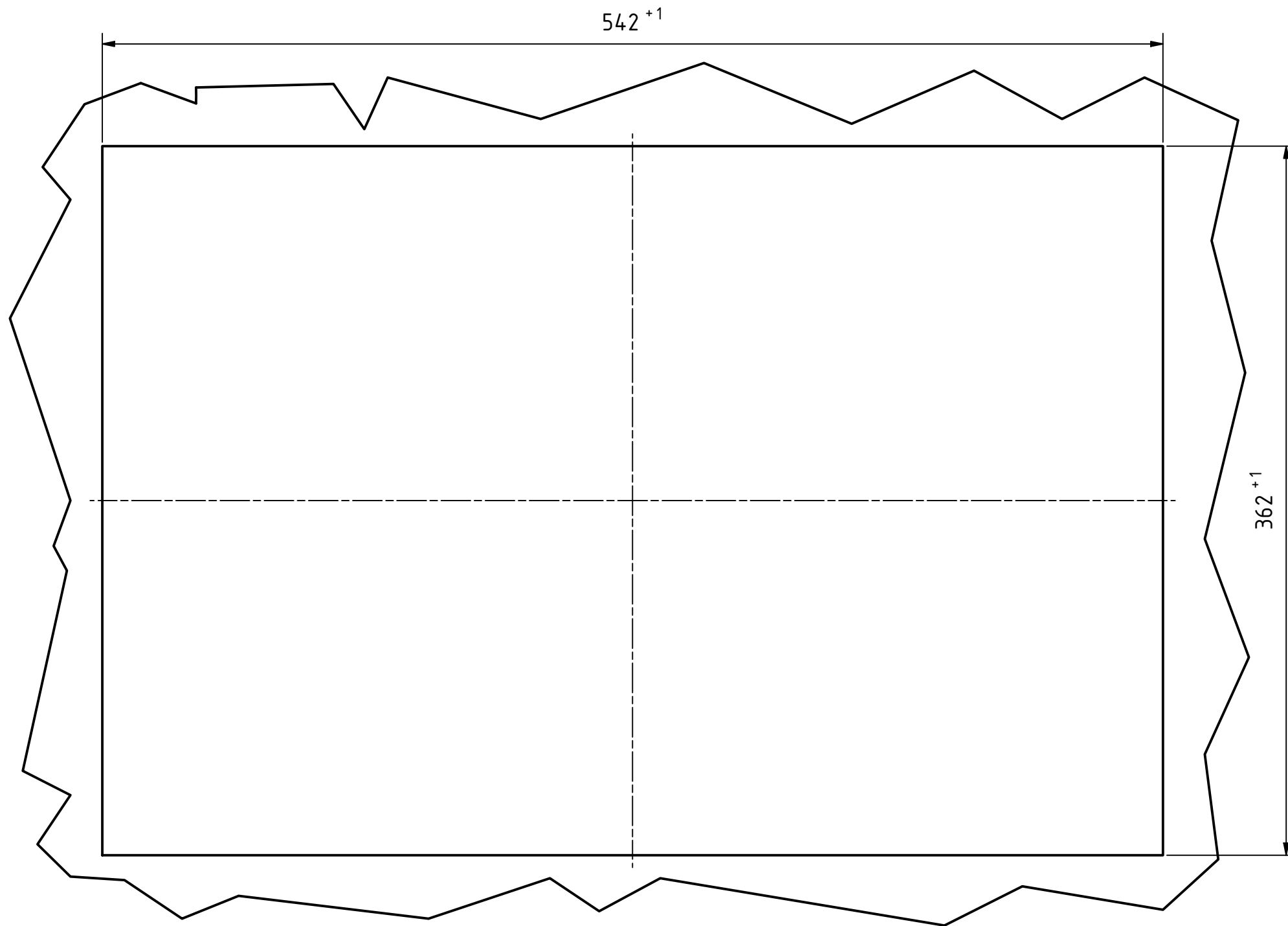

Tolerierung [Tolerancing] ISO 8015		alle Maße in mm [all dimensions in mm]		Maßstab [Scale] 1 : 2,5		DIN A3	
E-Mail: info@trsystems.de		CAD: STEP					
		Datum	Name	Bezeichnung [Designation]: _NOTION.S_CPUa7_21,5 (FULLHD)			
		Erst.	25.08.2025 BLESSING				
		Bearb.	25.08.2025 BLESSING				
		Gepr.	10.09.2025 AIPLE				
		Norm					
				Zeichnung-Nr. [Drawing-No.]: 778-11970-00		QR Code	
Zust.	Änderungen	Datum	Name	TRsystems GmbH Eglshalde 16 D-78647 Trossingen Tel. +49 7425 228-0 www.trsystems.de		Dok.Art. IDW Teil-Dok. 000 Dok.Vs. 00 2/2 Bl.	