

Änderungen vorbehalten !

		TRsystems GmbH Eglishalde 16 D-78647 Trossingen Tel. +49 7125 228-0 www.trsystems.de		Werkstück- kanten ISO 13715		Maßstab 1 : 2,5 DIN A2	
				Material:			
				Name		_notion.D.terminal-HDMI 15,6	
		Datum		Name			
		Erstellt 13.01.2022		BLESSING			
		Bearb. 13.01.2022		BLESSING			
		Gepr.					
		Norm					
				Diese Zeichnung ist Eigentum von TR Electronic GmbH und darf ohne unsere Zustimmung nicht weiter- gegeben oder kopiert werden			
Zust.		Änderungen		Datum		Name	
						Blatt 1 4 Bl.	
						Dok.Art. IDW	
						Teil-Dok. 000	
						Dok.Vs. 00	

Option: BG Montage-Kit Einbau (778-90058)

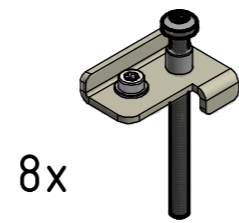

8x

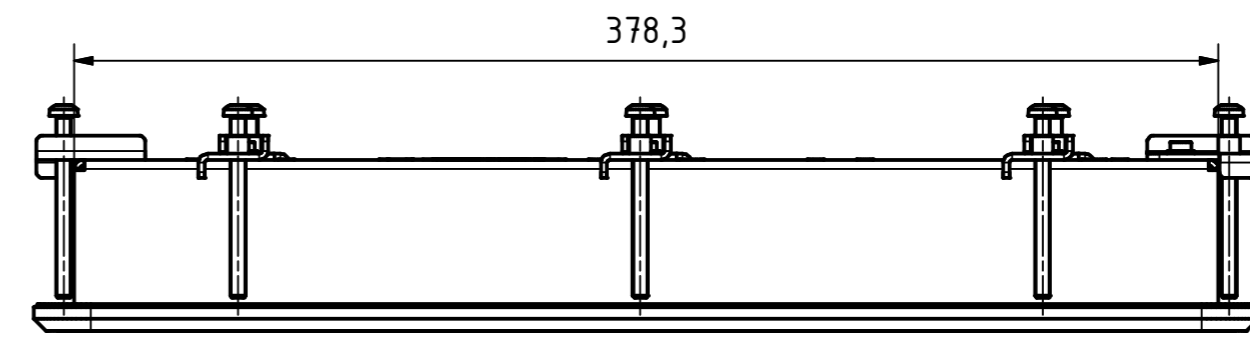

378,3

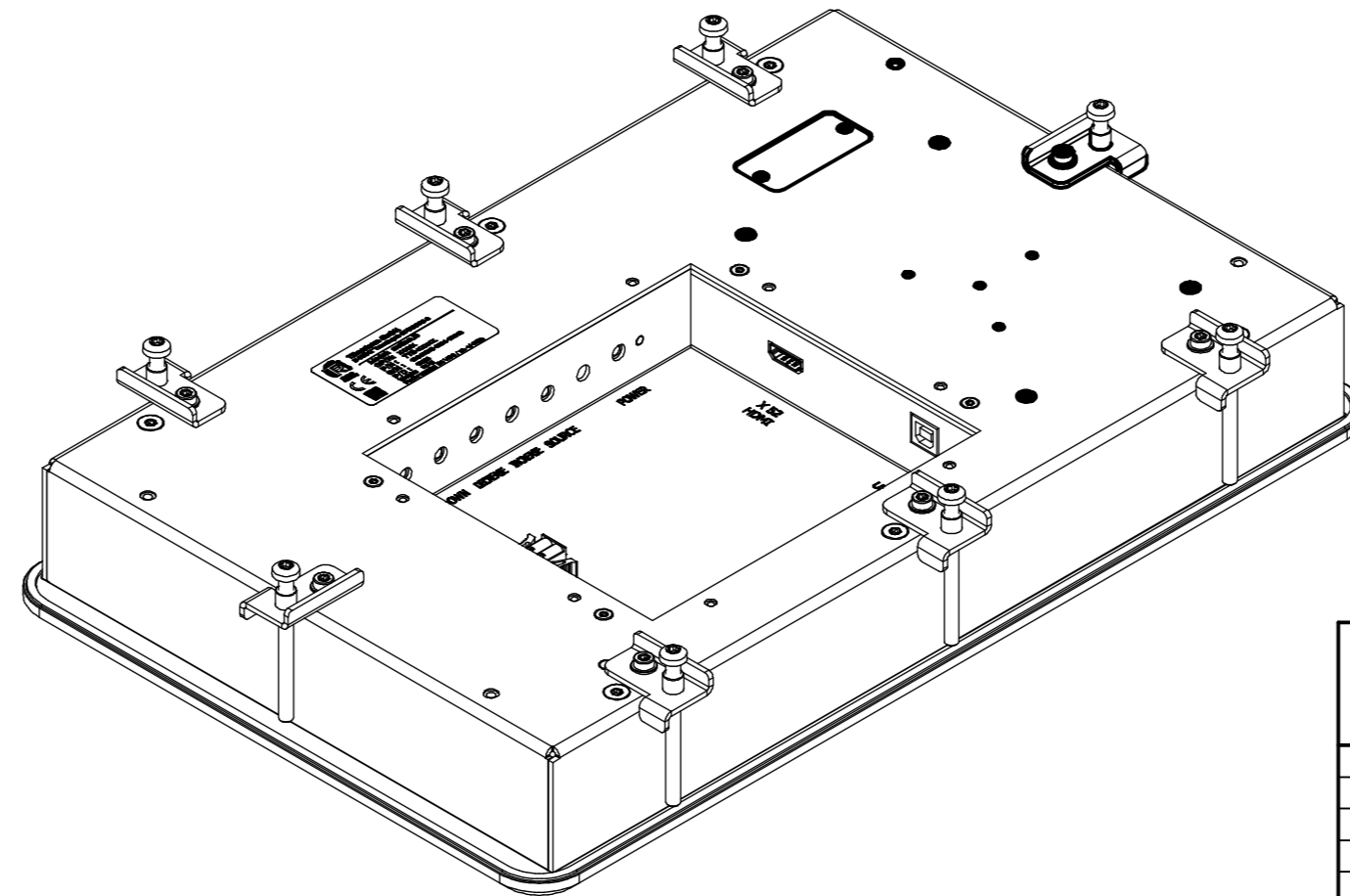
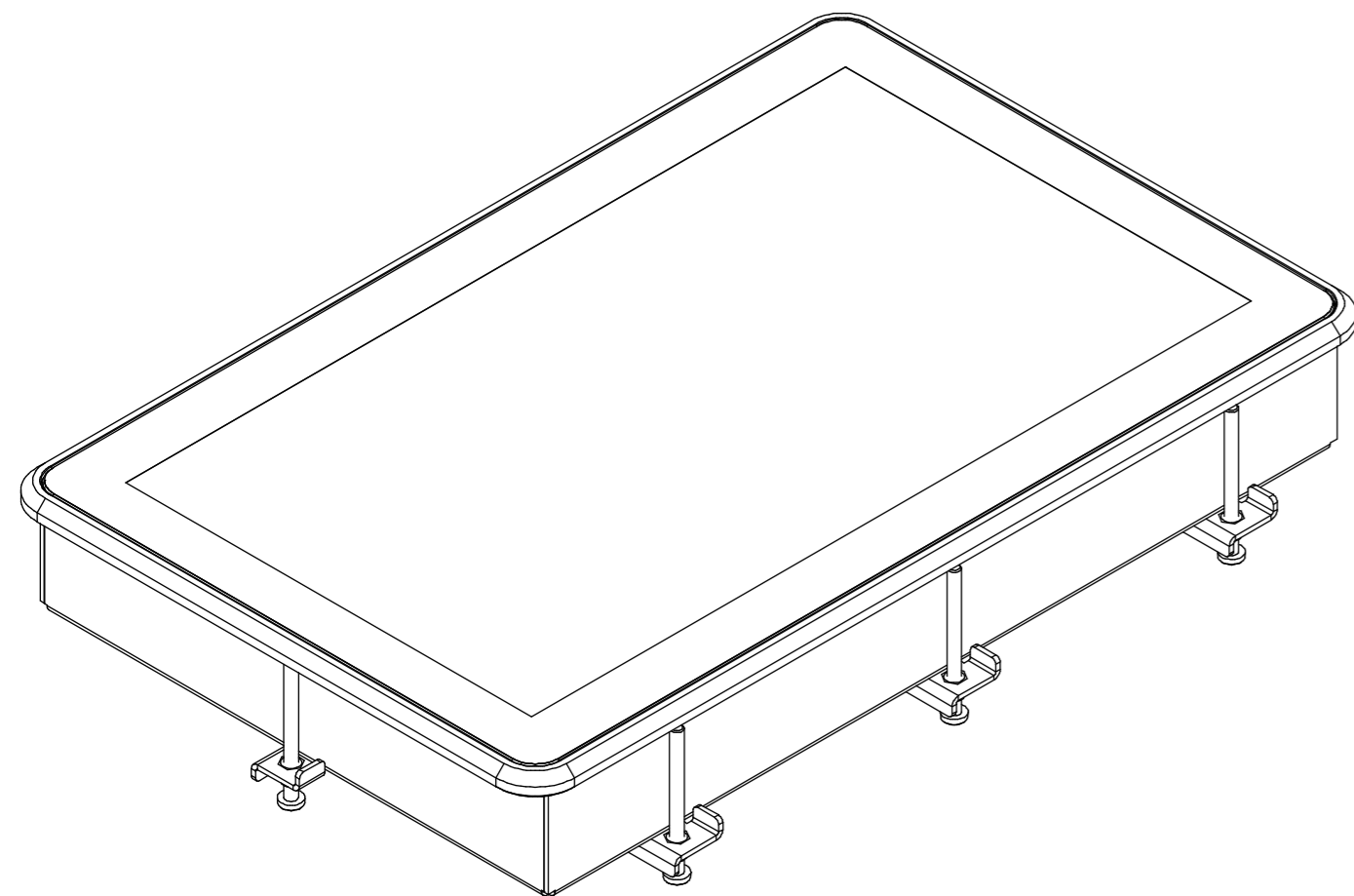
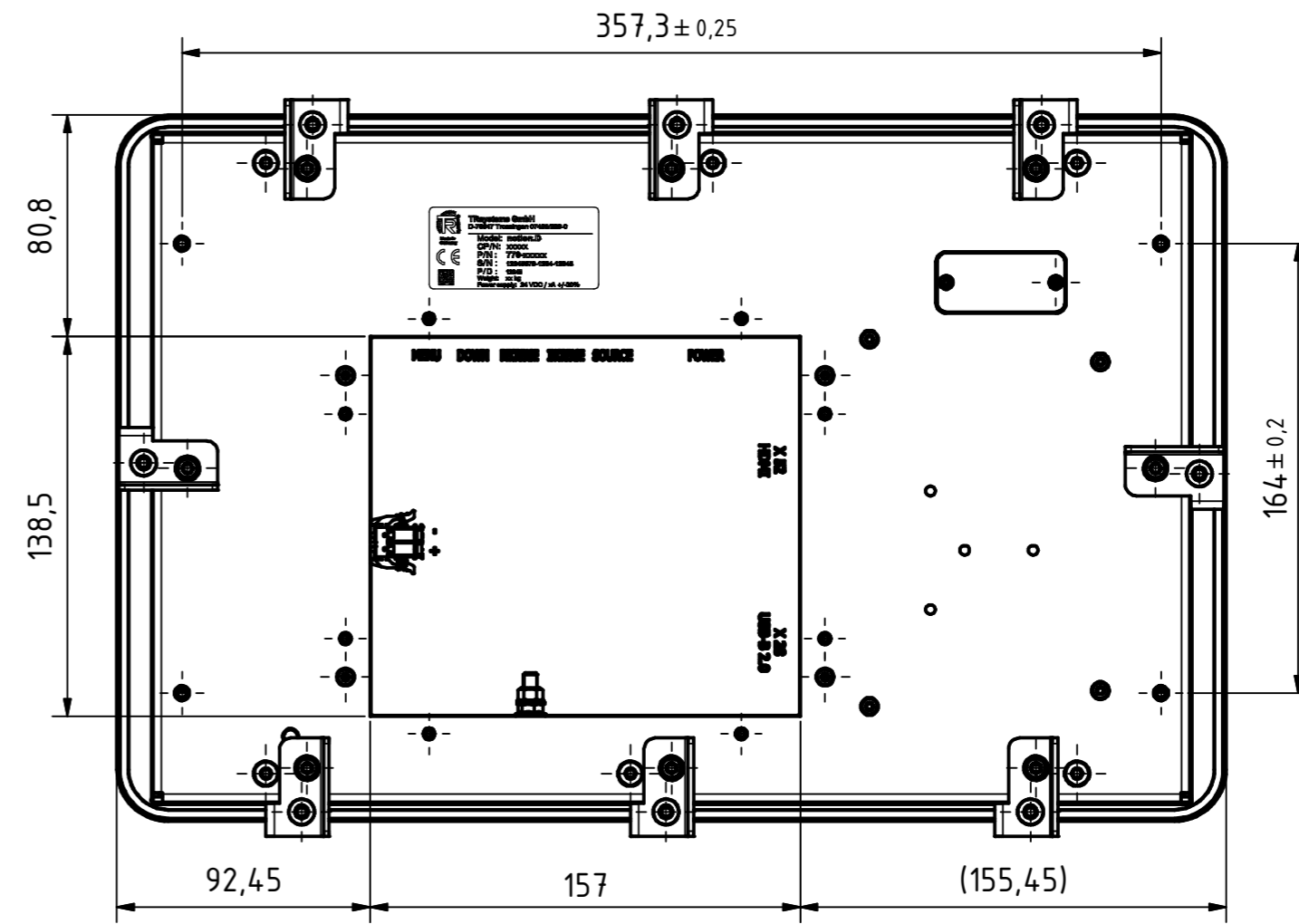
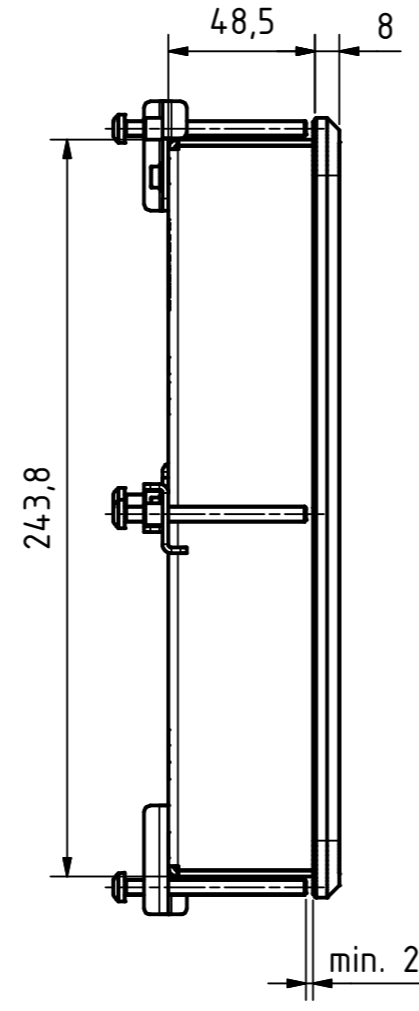
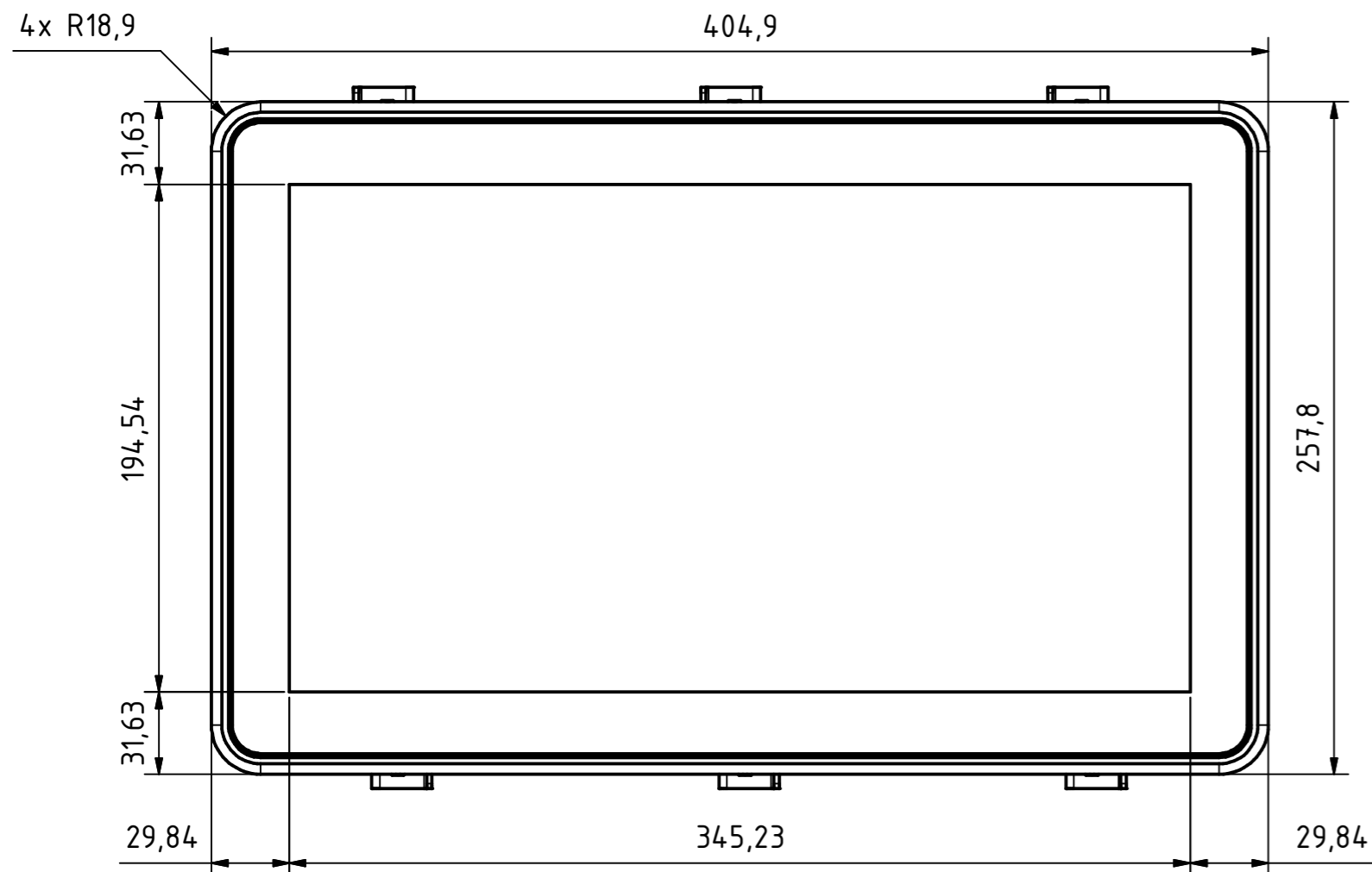

Änderungen vorbehalten !

	TRsystems GmbH Eglishalde 16 D-78647 Trossingen Tel. +49 71425 228-0 www.trsystems.de		Werkstück- kanten ISO 13715	Maßstab 1 : 2 DIN A2 Material:
	Name Datum	Name Datum	Name Datum	_notion.D.terminal-HDMI 15,6
Erstellt 13.01.2022 Bearb. 13.01.2022 Gepr. Norm	BLESSING BLESSING	BLESSING BLESSING	778-42991	
Diese Zeichnung ist Eigentum von TR Electronic GmbH und darf ohne unsere Zustimmung nicht weiter- gegeben oder kopiert werden	Blatt 2 4 Bl.	Dok.Art. IDW Teil-Dok. 000 Dok.Vs. 00	778-42991	

Option: IP54-Kit (778-90147)

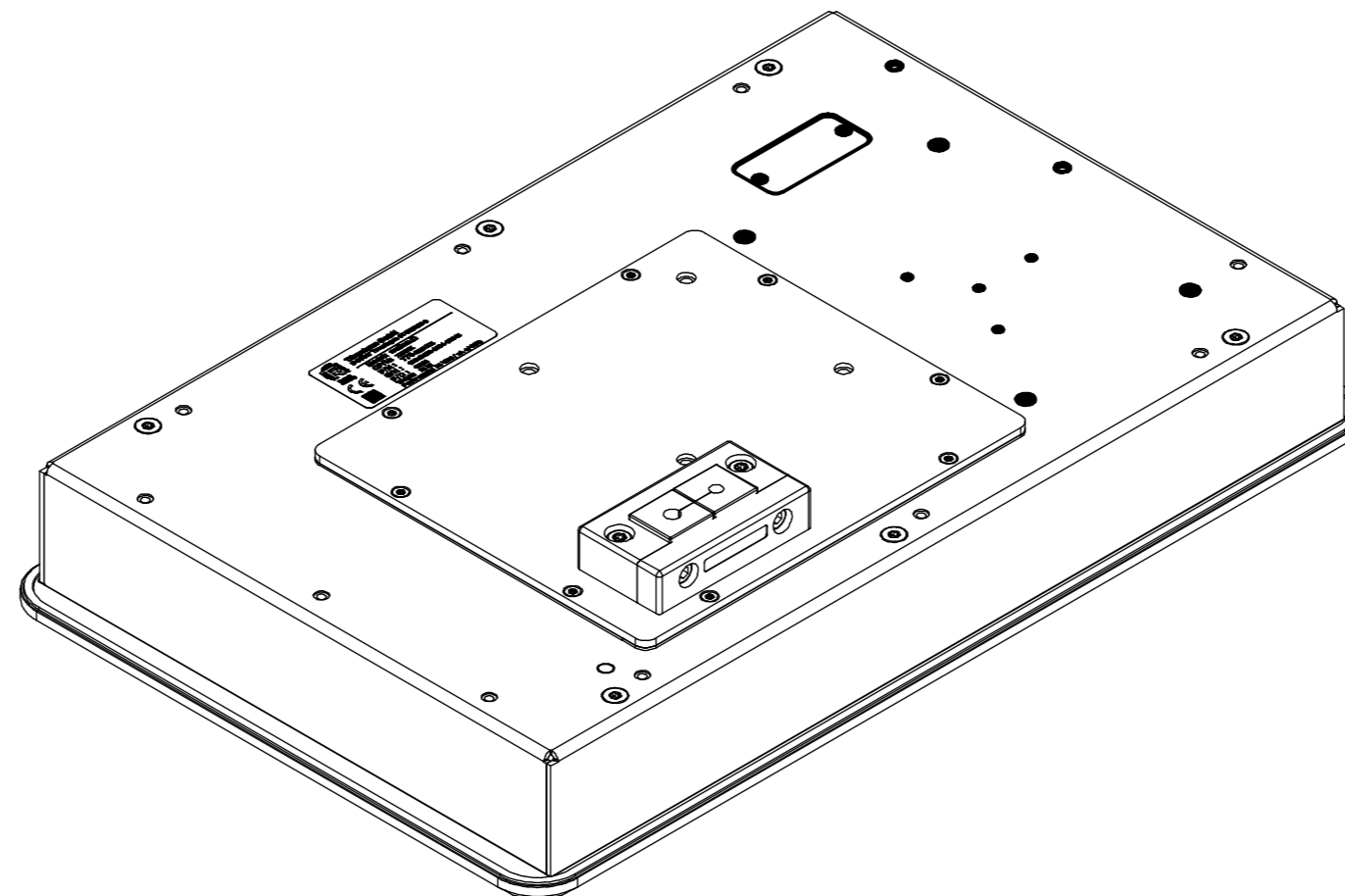
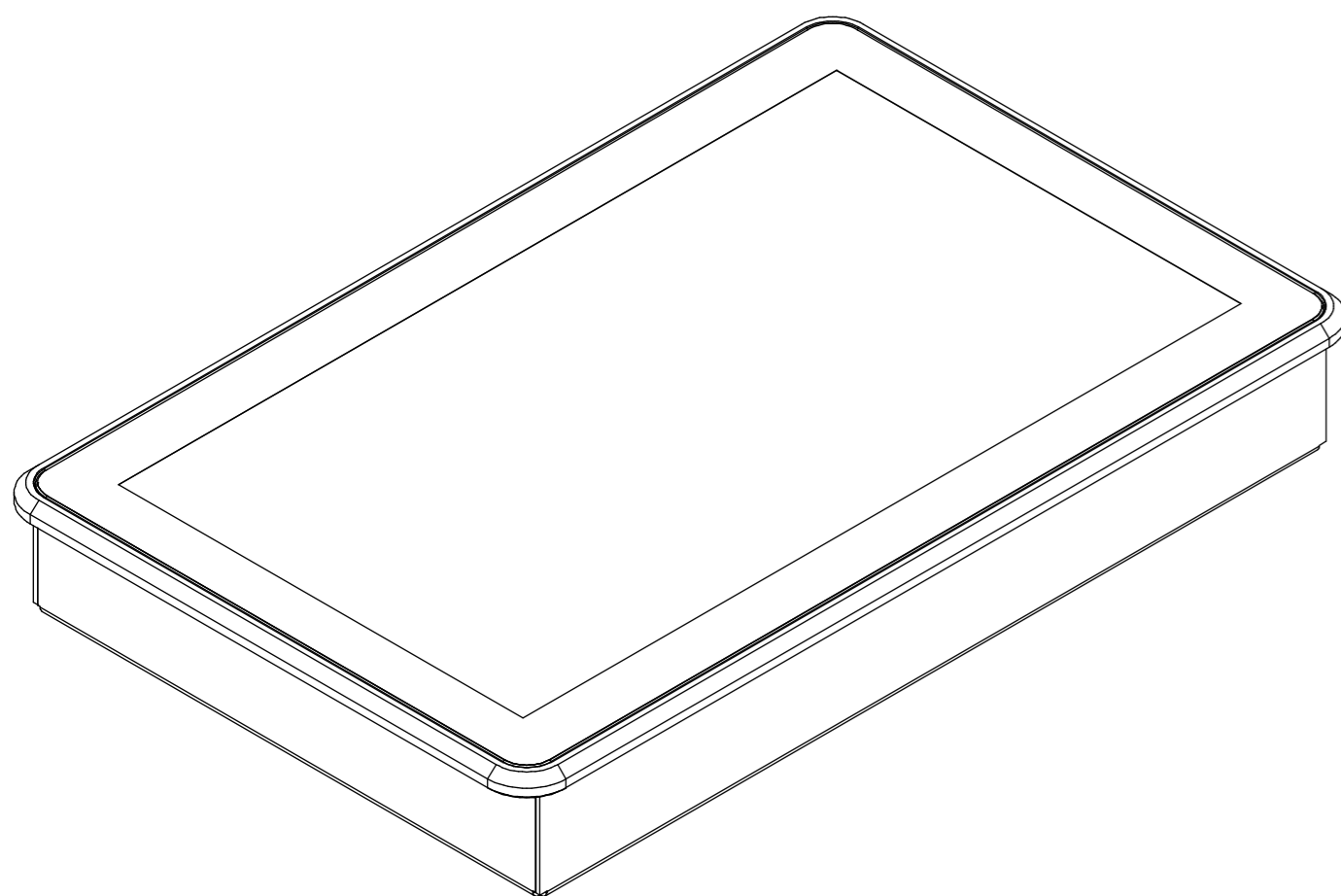
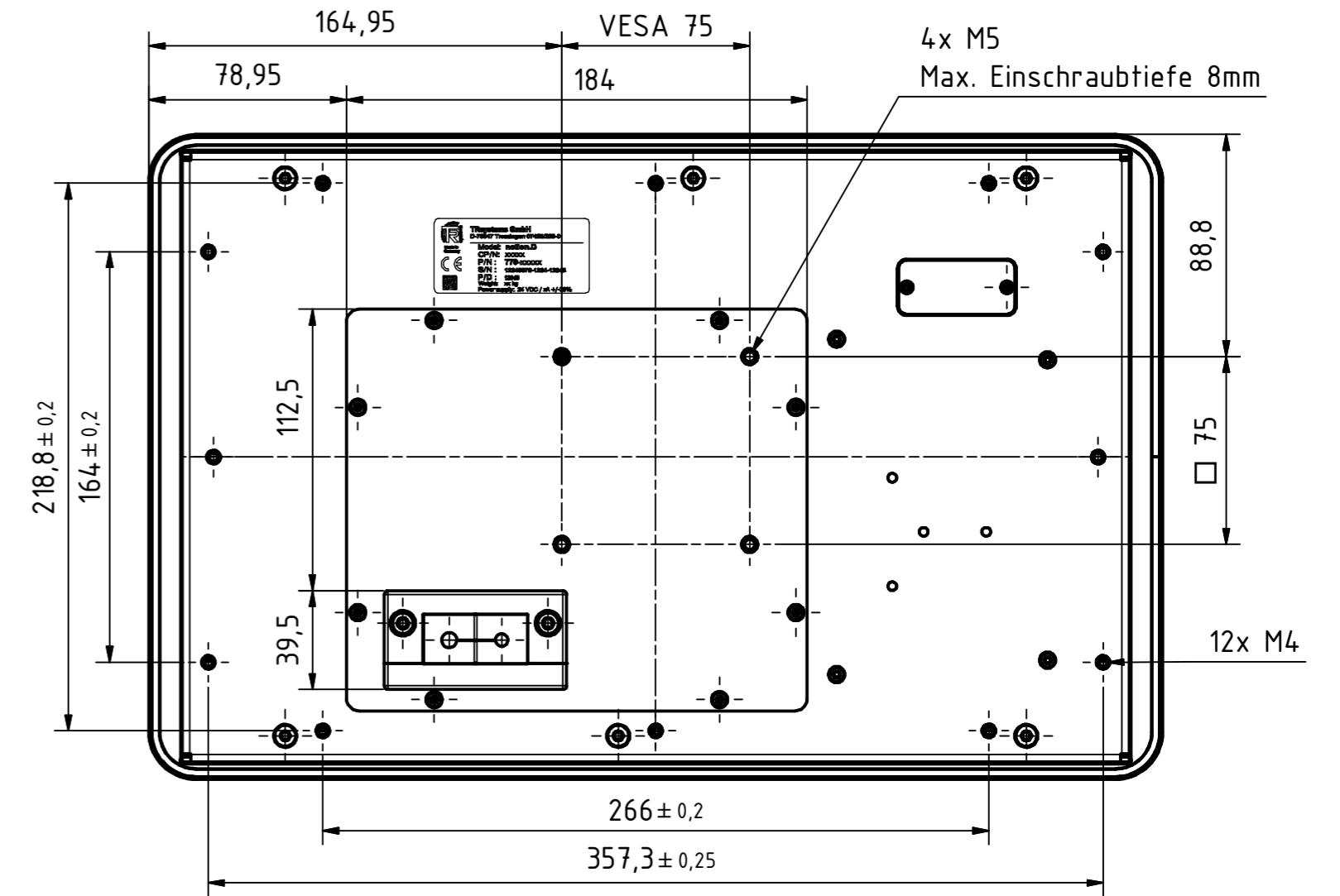
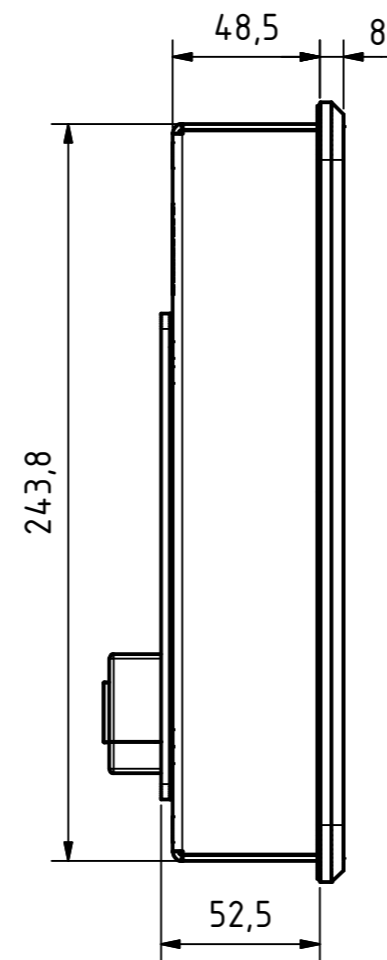
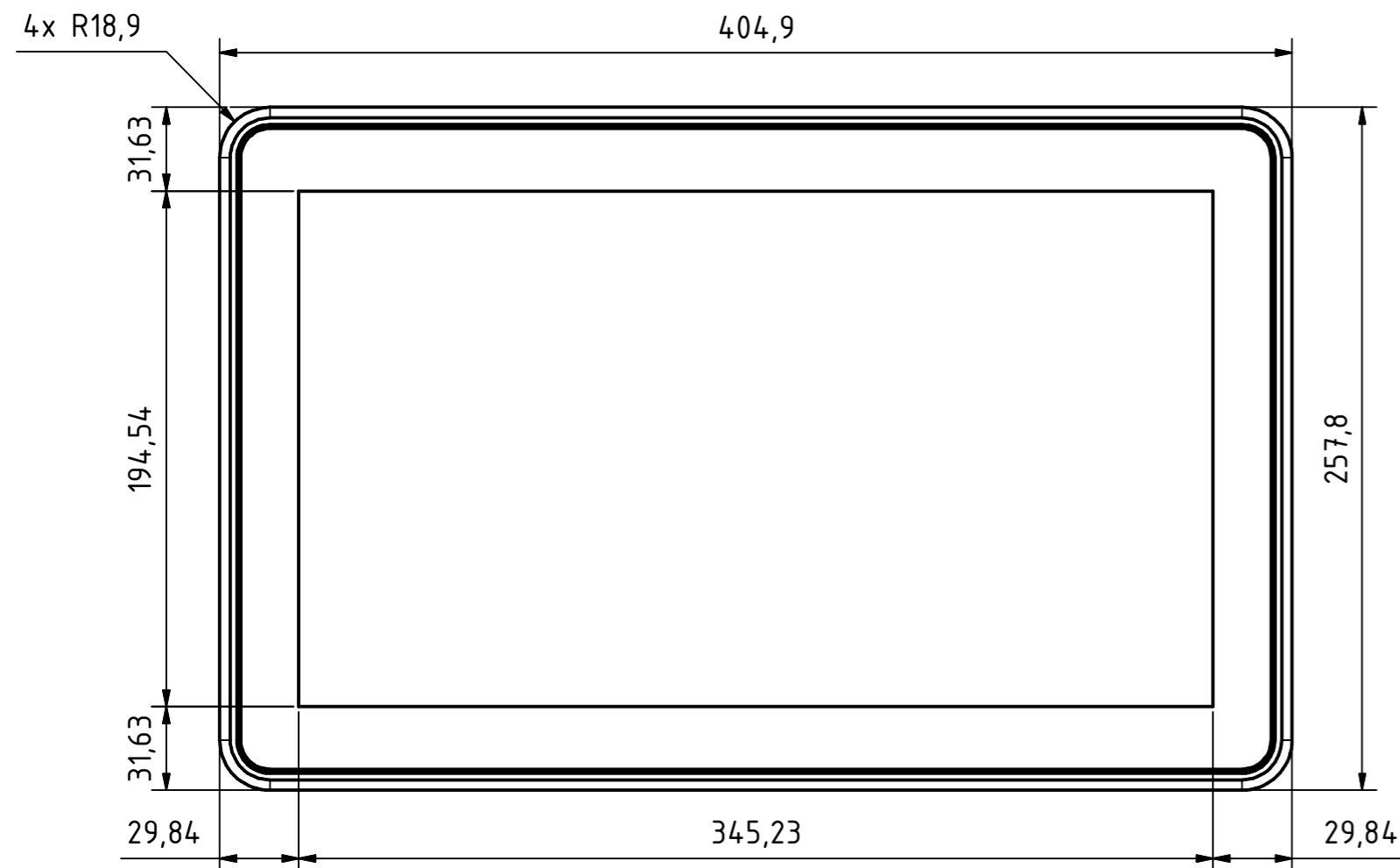
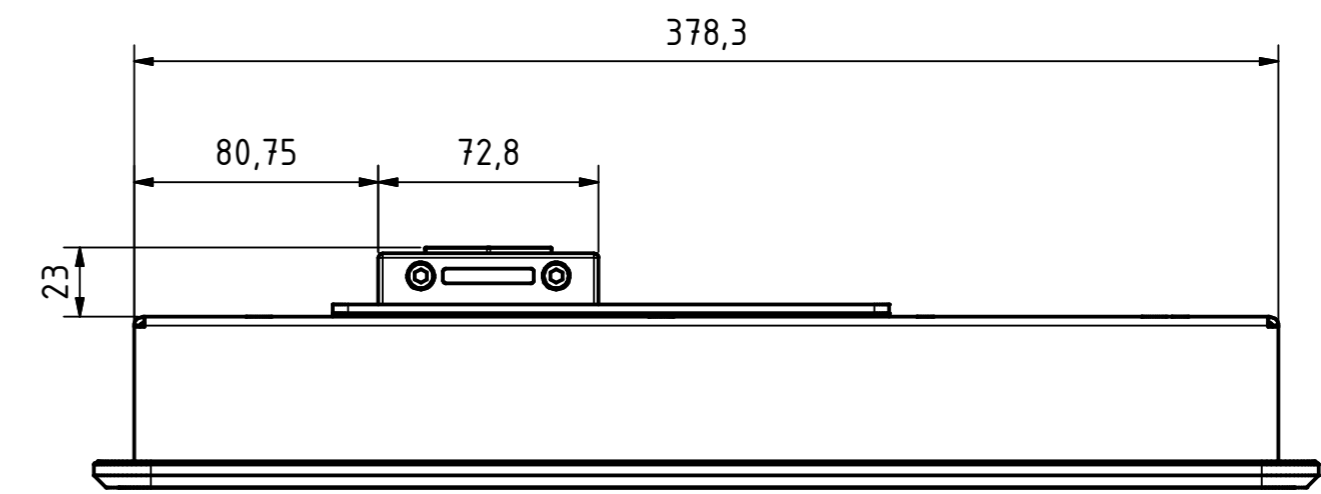
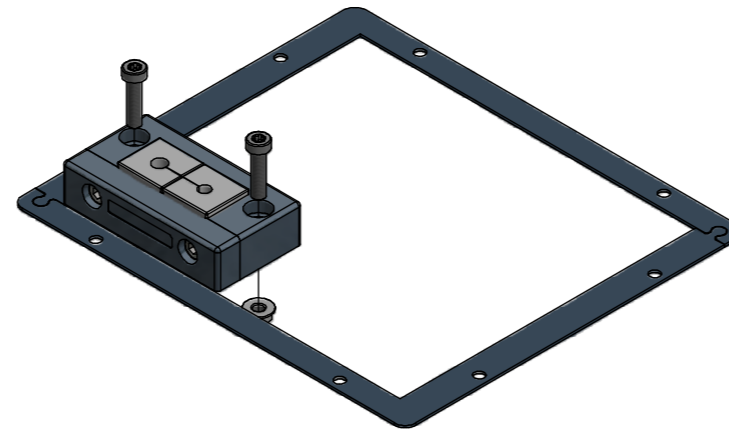

Änderungen vorbehalten!

	TRsystems GmbH Eglishalde 16 D-78647 Trossingen Tel. +49 7125 228-0 www.trsystems.de		Werkstück- kanten ISO 13715	Maßstab 1 : 2,5 DIN A2
	Diese Zeichnung ist Eigentum von TR Electronic GmbH und darf ohne unsere Zustimmung nicht weiter- gegeben oder kopiert werden			Material: _notion.D.terminal-HDMI 15,6
			Name Datum	
			Erstellt 13.01.2022 BLESSING Bearb. 13.01.2022 BLESSING Gepr. Norm	
				Blatt 3 4 Bl
Zust.	Änderungen	Datum	Name	Dok.Art. IDW Teil-Dok. 000 Dok.Vs. 00

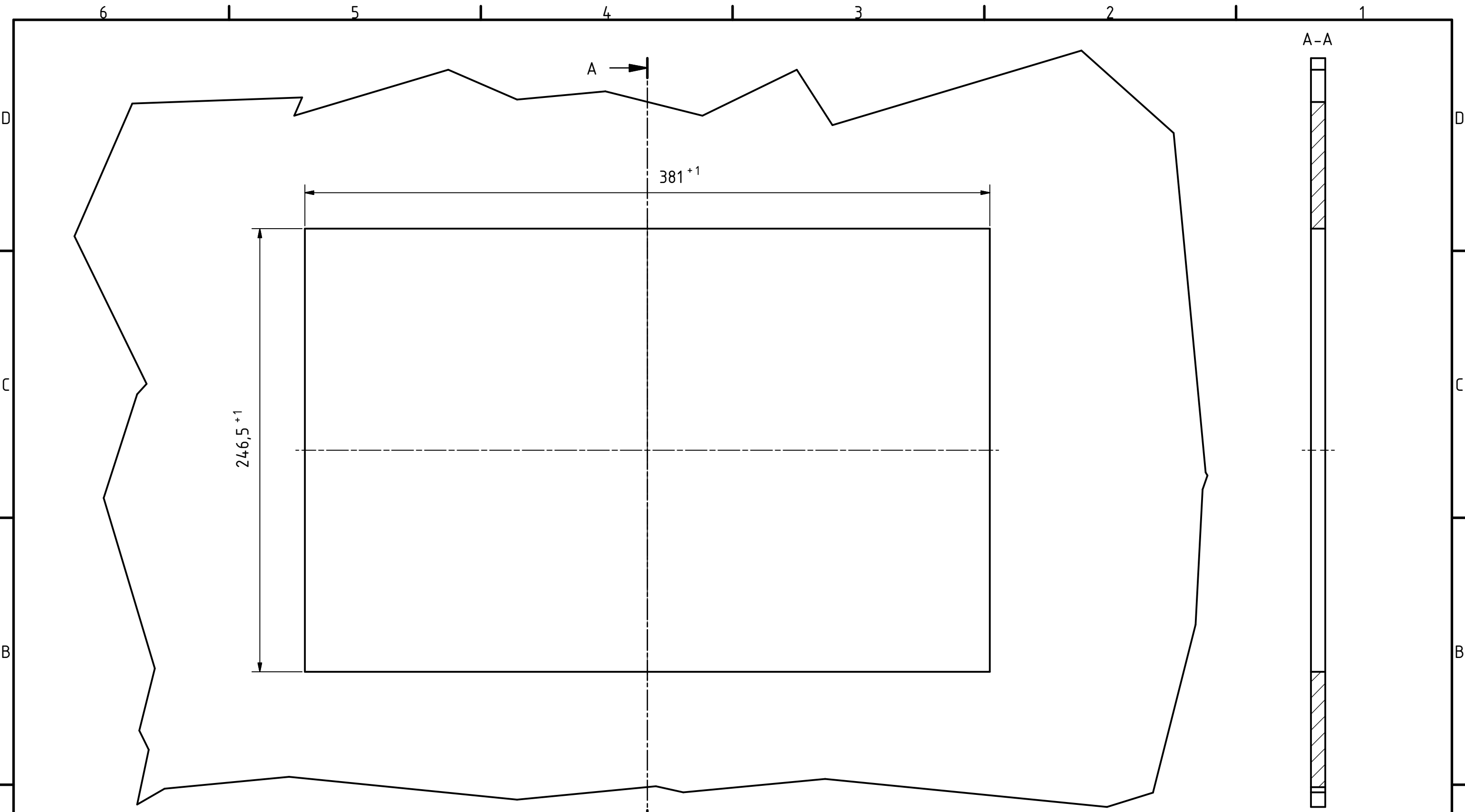

Änderungen vorbehalten !

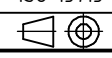
	TRsystems GmbH Eglshalde 16 D-78647 Trossingen Tel. +49 7425 228-0 www.trsystems.de		Werkstück- kanten ISO 13715 	Maßstab 1 : 2 DIN A3	Material:												
	<table border="1"> <thead> <tr> <th></th> <th>Datum</th> <th>Name</th> </tr> </thead> <tbody> <tr> <td>Erstellt</td> <td>13.01.2022</td> <td>BLESSING</td> </tr> <tr> <td>Bearb.</td> <td>13.01.2022</td> <td>BLESSING</td> </tr> <tr> <td>Gepr.</td> <td></td> <td></td> </tr> <tr> <td>Norm</td> <td></td> <td></td> </tr> </tbody> </table>		Datum	Name		Erstellt	13.01.2022	BLESSING	Bearb.	13.01.2022	BLESSING	Gepr.			Norm		
	Datum	Name															
Erstellt	13.01.2022	BLESSING															
Bearb.	13.01.2022	BLESSING															
Gepr.																	
Norm																	
Diese Zeichnung ist Eigentum von TR Electronic GmbH und darf ohne unsere Zustimmung nicht weitergegeben oder kopiert werden				778-42991	Blatt 4 4 Bl												
Zust.	Änderungen	Datum	Name	Dok.Art. IDW	Teil-Dok. 000	Dok.Vs. 00											